

At JVS, multistage choke trim has been introduced to cope up with the significant pressure drop inherent in wellhead start up, whilst also providing minimal flow restriction during operation.

Multistage is most suitable for initial high pressure drop, low flow conditions which then change gradually to low pressure, high flow. It is a combination of disc & flow cage design with multi-hole geometry to handle tri linear characteristic.

The additional feature of above designated multistage is that the trim can be specified with control valves or retrofitted to existing valve bodies. In all cases the multistage trim secures the valve seat without the use of a clamping cage and in turn increasing the seat bore to maximize capacity as well as through output.

Developed based on years of practical experience of providing choke application solutions throughout the world. The multistage trim consists of two well-defined sections:

- The start-up section, comprising approximately the first 10% to 30% of travel, determined by the well pressure/flow profile. It directs the flow through ports designed to impart significant friction on the fluid, resulting into lower velocities and reduced pressure recovery characteristics. Valve noise, erosion and vibration are within acceptable limit. This will increase the operational life of the choke.
- The multistage is designed to overcome specific operating characteristics in wellhead and associated applications like sour gas production, high pressure crude oil production, water injection and similar application.

Plug head is always pressure balanced & provisions are made at bonnet to handle high pressure.

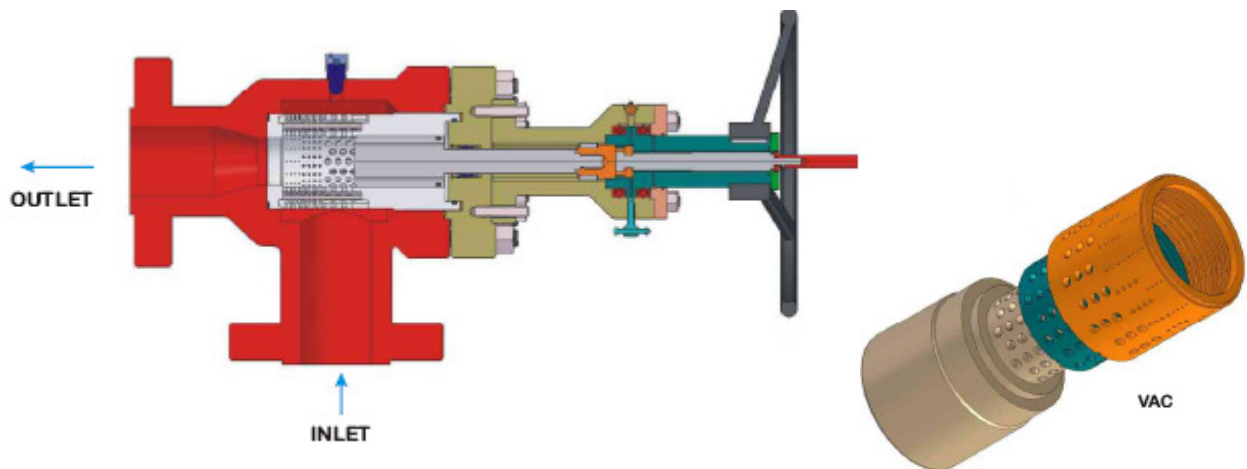

Note: This is for understanding only. Please refer to JVS for detailed design & technical information.



| | |
|---------------|--------------|
| Written By | R. B. Parmar |
| Checked by | J. V. Mistry |
| Approved By | V. M. Shah |
| Revision | 00 |
| Rev./Rel. Dt. | 04/05/2009 |
| Page | Page 2 of 2 |

VAC (Anti Cavitation)

Trims utilize 2 or more ported cages to reduce pressure in stages. Cages are shrink fitted with each other in line with designed flow path. These trims are used primarily in anti cavitation service for water injection and water dumping.



By using a special retainer that controls where the cavitation takes place, it is possible to prevent serious damage occurring to the components provided the conditions are not too severe.

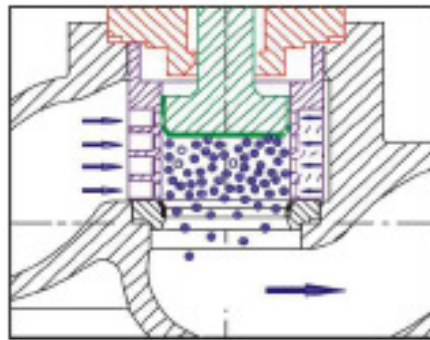

Three methods of combating cavitation

- Increase the life of valve by making vulnerable components more wear resistant.
- Control where the vapor bubbles collapse keeping them away from the valve body and trim.
- Ensure that the internal pressure of the fluid does not fall below the vapor pressure eliminating the formation of vapor bubbles.

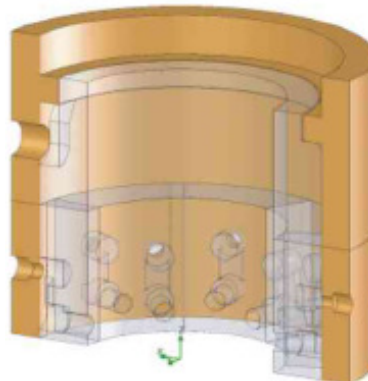

Note: This is for understanding only. Please refer to JVS for detailed design & technical information.